

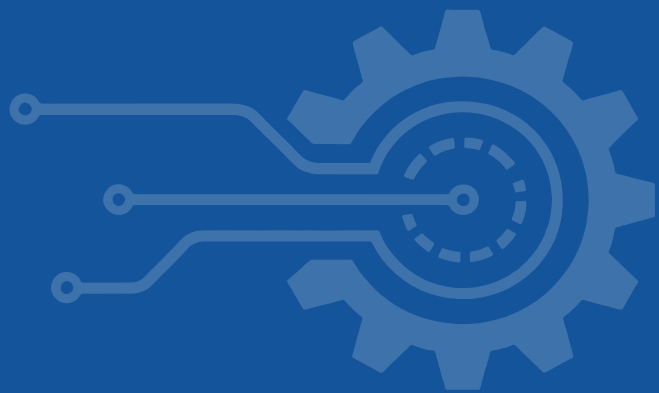

BOMAO

缔造 +
直流电源整体解决方案

Create Total Solutions for DC Power Supplies



上海博贸自动化科技有限公司

Shanghai Bomao Automation Technology Co. , Ltd.



关于我们

About us



COMPANY PROFILE

企业简介

上海博贸自动化科技有限公司是“工业控制解决方案”的系统集成商、“工业控制与应用电气”的专业制造商。主要产品覆盖交流功率调节器、EDI 直流电源、电化学水处理直流电源、大功率直流电源成套设备等，产品广泛应用于电力、冶金、石油石化、军工业、矿山、化工、建筑、建材、轻工业、制药、市政、纺织印染、造纸、橡塑、电气化铁路等行业。

Shanghai Bomao Automation Technology Co., Ltd. is a system integrator of industrial control solutions, a professional manufacturer of industrial control and Applied Electric Control. The main products cover AC power regulator, EDI DC power supply, electrochemical water treatment DC power supply, HIGH-POWER DC power complete sets of equipment, etc. Products are widely used in electric power, metallurgy, petroleum and petrochemical, military industry, mining, chemical, construction, building materials, light industry, pharmaceutical, municipal, textile printing and dyeing, paper, rubber, plastic, railway electrification system and other industries.

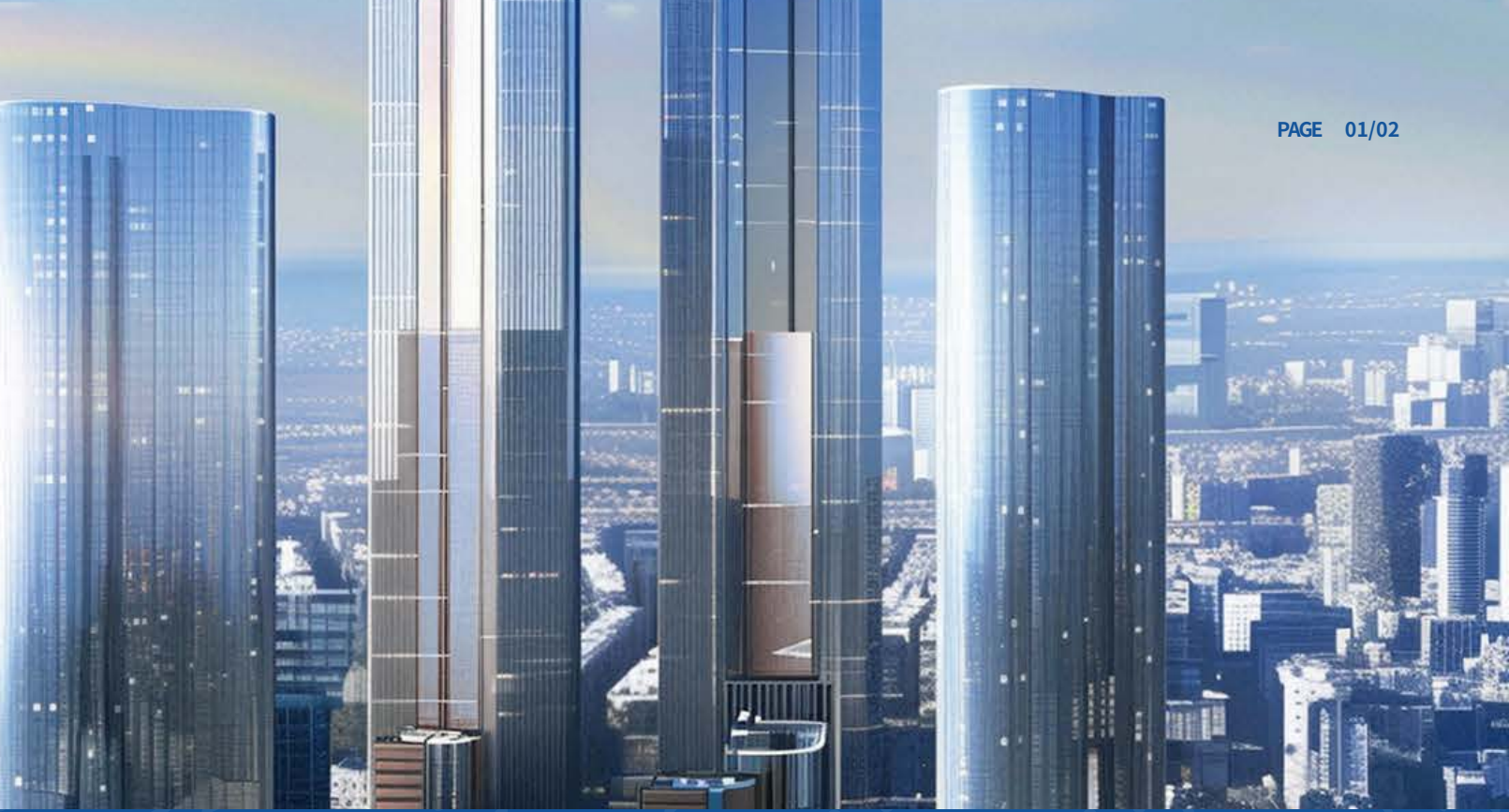

DEVELOPMENT PHILOSOPHY

企业发展理念与战略愿景

公司将不断地开发出节能、高效、精密、人性化的产品，以专业独特的工控技术、领先适用的创新产品以及深度整合的解决方案，帮助用户实现经济转型和产业升级，并加快国际化步伐，用品质征服世界，立志成为享誉全球的智能电气专业供应商！

The company will continue to develop energy-saving, efficient, precision, human-oriented products, professional and unique industrial control technology, leading innovative products and deep integration of solutions to help users achieve economic transformation and industrial upgrading And speed up the pace of internationalization, with the quality of world conquest, determined to become a world-renowned smart electrical professional suppliers!

EDI直流电源

EDI DC controller



适用所有品牌EDI膜堆 适用所有流量大小EDI膜堆
Applicable to all brands of EDI membrane stacks; Applicable to all flow rate sizes of EDI membrane stacks.

产品功能特点:

Product Features:

- 单一规格设计,主电源于260-480VAC范围内皆可使用
- 电源频率自我侦测,50-60HZ均可使用,不需任何选择或切换。
- 两种控制模式:恒电流、恒电压;可自由切换
- 通讯采用隔离式RS-485(MODBUS RTU)通讯,可连接250台
- 显示表采用网线快速连接,免于外部配线。
- 具有:过电流、超温、断水、启动和停止状态检测并有一组警报干接点输出。
- 主回路电源单相接线和三相接线自动侦测,无需设置。
- 输出电流和电压,4-20MA模拟量变送输出可选择
- 适用所有规格EDI模块
- 提供多种尺寸显示表

Single specification design, with the main power supply operating within the 260-480 VAC range.
Automatically detects power frequency, compatible with both 50Hz and 60Hz without requiring any selection or switching.
Two control modes: constant current, constant voltage; freely switchable.
The communication employs isolated RS-485 (MODBUS RTU) communication, capable of connecting up to 250 units.
The display panel utilizes a network cable for quick connection, eliminating the need for external wiring.
Features: Overcurrent, overtemperature, water shortage, start/stop status detection, and a set of alarm dry contact outputs.
Automatic detection of single-phase and three-phase main circuit power connections, no configuration required.
Output current and voltage, with optional 4-20mA analog transmitter output.
Applicable to all EDI module specifications.
Available in multiple sizes.

产品型号识别表

Table of Product ID

型号 Model	M9200-A	M9300-A
输入 input	260VAC-480VAC	260VAC-480VAC
输出 output	350-635VDC	350-635VDC
电流 current	15A	20A

显示表规格

Display table specifications

A:96*96	B:48*96	C:96*48
---------	---------	---------

外形图

outline drawing

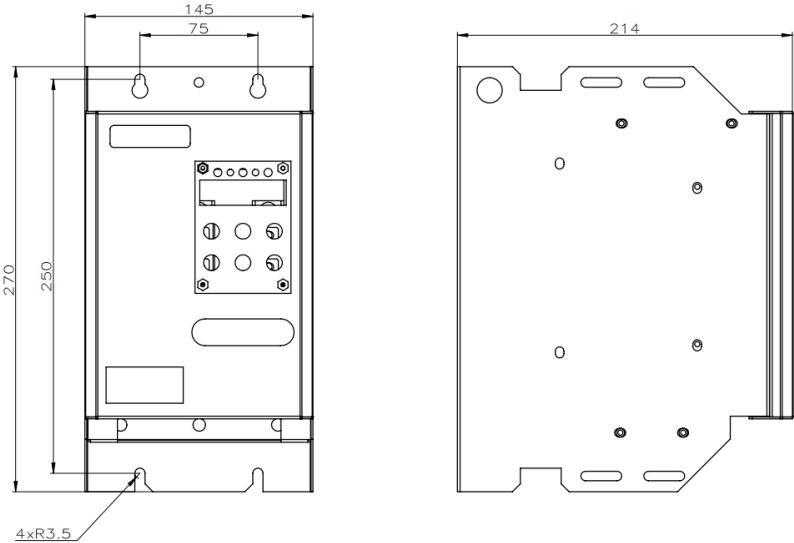

接线图

Wiring Diagram

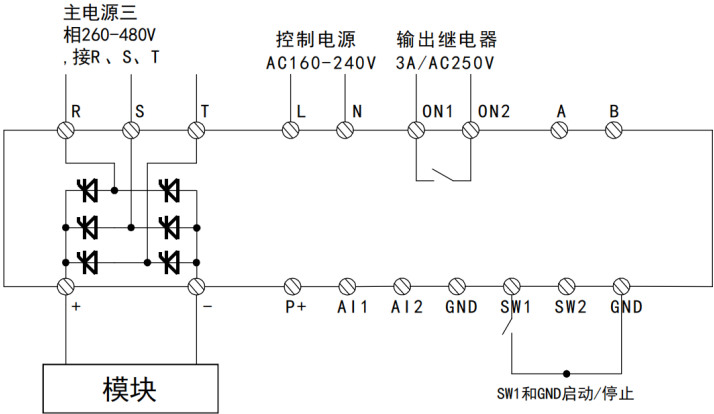

Partial engineering case presentation

部分工程案例展示

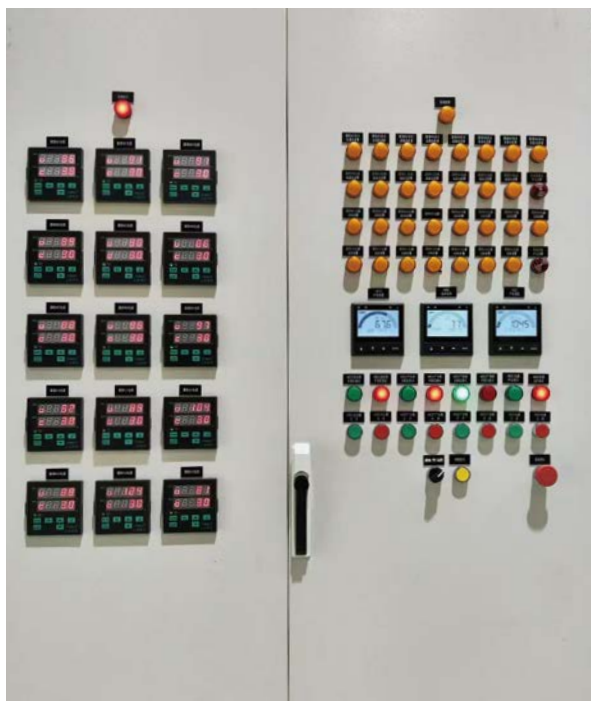





马来西亚电源项目

Characteristics of module DC power supply:



巴西船舶项目

Characteristics of module DC power supply:



次氯酸钠发生器

Characteristics of module DC power supply:



出口越南大型整流电源系统

Characteristics of module DC power supply:



国内玻璃纤功率控制系统

Characteristics of module DC power supply:



台湾电力公司项目

Characteristics of module DC power supply:



国内某军工电源项目

Characteristics of module DC power supply:



出口油冷直流电源系统

Export oil cooled DC power supply system

BOMMAO

上海博贸自动化科技有限公司

Tel: 213 466 1160

Fax: 213 466 1170

Web: www.shbomao.com

Add: 上海市青浦区华隆路1758号10楼